

# SPH-QSFP+CX

## 40G QSFP+ COPPER CABLE



### Features

- Compliant QSFP MSA specifications
- Fully compatible with IEEE802.3ba and Infiniband QDR specifications
- 40 Gb/s total bandwidth
- 4 independent duplex channels operating at 10Gbps, also support for 2.5Gbps, 5Gbps data rates
- 100 ohm differential impedance system
- Single 3.3V power supply, low power consumption<1.5W
- Low Near-End Crosstalk(NEXT)
- Operating case temperature: 0 to 70°C
- All-metal housing for superior EMI performance
- Precision process control for minimization of pair-to-pair skew
- AC coupling of PECL signals
- EEPROM for cable signature & system communications
- 30 AWG to 24 AWG cable sizes available
- RoHS compliant

### Applications

#### Data

- Networked storage systems

- Routers
- External storage systems
- Data Center networking

### Communications

- Switches
- Routers

### Industry Standards

- InfiniBand Trade Association (IBTA)
- IEEE802.3ba
- 40 Gigabit Ethernet (40G BASE – CR4)

## Description

SOPTO QSFP+ (Quad Small Form-factor Pluggable Plus) copper direct-attach cables are suitable for very short distances and offer a highly cost-effective way to establish a 40-Gigabit link between QSFP+ ports of QSFP+ switches within racks and across adjacent racks. These cables are used for 40GbE and Infiniband standards, to maximize performance. QSFP+ are designed to meet emerging data center and high performance computing application needs for a high density cabling interconnect system capable of delivering an aggregate data bandwidth of 40Gb/s. This interconnect system is fully compliant with existing industry standard specifications such as the QSFP MSA and IBTA (InfiniBand Trade Association). The QSFP+ cables support the bandwidth transmission requirements as defined by IEEE 802.3ba (40 Gb/s) and Infiniband QDR ( 4x10 Gb/s per channel) specifications.

## Absolute Maximum Ratings

Parameter	Symbol	Min	Max	Unit	Note
Storage Temperature	Tst	-40	125	degC	
Relative Humidity (non-condensation)	RS	-	85	%	
Operating Case Temperature	Topc	0	70	degC	1
Supply Voltage	VCC3	-0.3	3.6	V	
Voltage on LVTTTL Input	Vilvttl	-0.3	VCC3 +0.2	V	

**NOTE:** Stress or conditions exceed the above range may cause permanent damage to the device. This is a stress rating only and functional operation of the device at these or any other conditions above those listed in the operational sections of this specification is not applied. Exposure to absolute maximum rating conditions for extended periods may affect device reliability.

## Recommended Operating Conditions

Parameter	Symbol	Min	Max	Unit
Operating Case Temperature	Topc	0	70	degC
Relative Humidity (non-condensation)	RS	-	85	%
Supply Voltage	VCC3	3.135	3.465	V
Power Supply Current	ICC3	750	-	mA
Total Power Consumption	Pd	-	2.0	W

### Pin Assignments and Descriptions

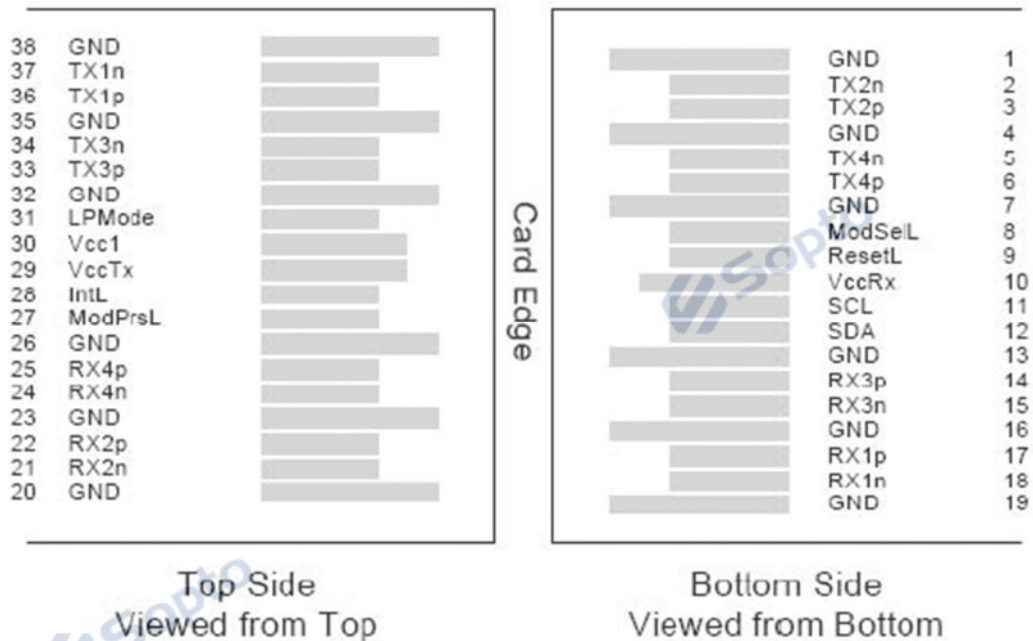

PIN	Logic	Symbol	Name/Description	Note
1		GND	Ground	1
2	CML-I	Tx2n	Transmitter Inverted Data Input	
3	CML-I	Tx2p	Transmitter Non-Inverted Data output	
4		GND	Ground	1
5	CML-I	Tx4n	Transmitter Inverted Data Input	
6	CML-I	Tx4p	Transmitter Non-Inverted Data output	

7		GND	Ground	1
8	LVTLL-I	ModSelL	Module Select	
9	LVTLL-I	ResetL	Module Reset	
10		Vcc Rx	+ 3.3V Power Supply Receiver	2
11	LVCMOS-I/ O	SCL	2-Wire Serial Interface Clock	
12	LVCMOS-I/ O	SDA	2-Wire Serial Interface Data	
13		GND	Ground	
14	CML-O	Rx3p	Receiver Non-Inverted Data Output	
15	CMLO	Rx3n	Receiver Inverted Data Output	
16		GND	Ground	1
17	CMLO	Rx1p	Receiver Non-Inverted Data Output	
18	CMLO	Rx1n	Receiver Inverted Data Output	
19		GND	Ground	1
20		GND	Ground	1
21	CMLO	Rx2n	Receiver Inverted Data Output	
22	CMLO	Rx2p	Receiver Non-Inverted Data Output	
23		GND	Ground	1
24	CMLO	Rx4n	Receiver Inverted Data Output	1
25	CMLO	Rx4p	Receiver Non-Inverted Data Output	
26		GND	Ground	1
27	LVTTL0	ModPrsL	Module Present	
28	LVTTL0	IntL	Interrupt	
29		Vcc Tx	+3.3 V Power Supply transmitter	2
30		Vcc1	+3.3 V Power Supply	2
31	LVTTLI	LPMODE	Low Power Mode	
32		GND	Ground	1
33	CMLI	Tx3p	Transmitter Non-Inverted Data Input	
34	CMLI	Tx3n	Transmitter Inverted Data Output	

35		GND	Ground	1
36	CMLI	Tx1p	Transmitter Non-Inverted Data Input	
37	CMLI	Tx1n	Transmitter Inverted Data Output	
38		GND	Ground	1

**Note:**

1. GND is the symbol for signal and supply (power) common for QSFP modules. All are common within the QSFP module and all module voltages are referenced to this potential otherwise noted. Connect these directly to the host board signal common ground plane.
2. Vcc Rx, Vcc1 and Vcc Tx are the receiver and transmitter power suppliers and shall be applied concurrently. Recommended host board power supply filtering is shown below. Vcc Rx, Vcc1 and Vcc Tx may be internally connected within the QSFP transceiver module in any combination. The connector pins are each rated for a maximum current of 500mA.

**Recommended power supply filtering Example of QSFP Host board**

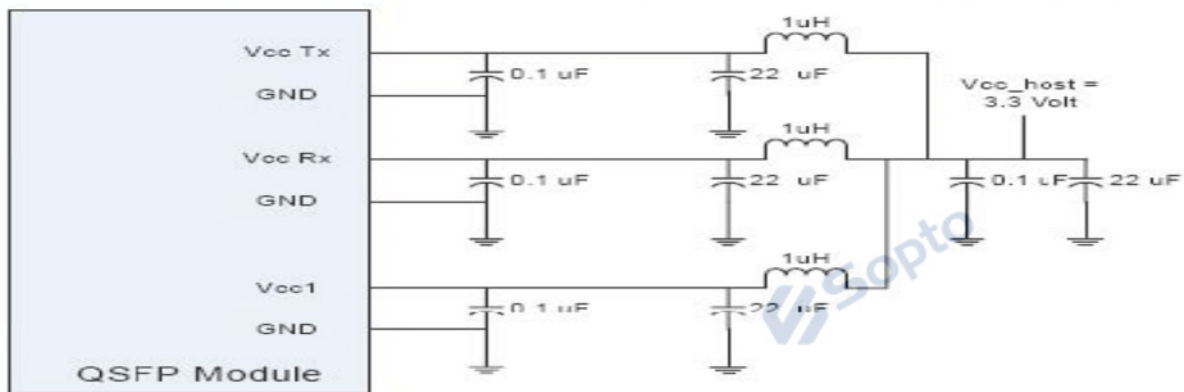

A typical host board mechanical layout for attaching the QSFP transceiver is presented below. The recommended host electrical connector should be a 38-pin IPASS right angle connector assembly (example: Tyco PN: 1761987-9) and the cage assembly should be QSFP single cage (example: Tyco PN: 1888617-1).

**Recommended PCB layout**

A typical host board mechanical layout for attaching the QSFP transceiver is presented below. The recommended host electrical connector should be a 38-pin IPASS right angle connector assembly (example: Tyco PN: 1761987-9) and the cage assembly should be QSFP single cage (example: Tyco PN: 1888617-1).

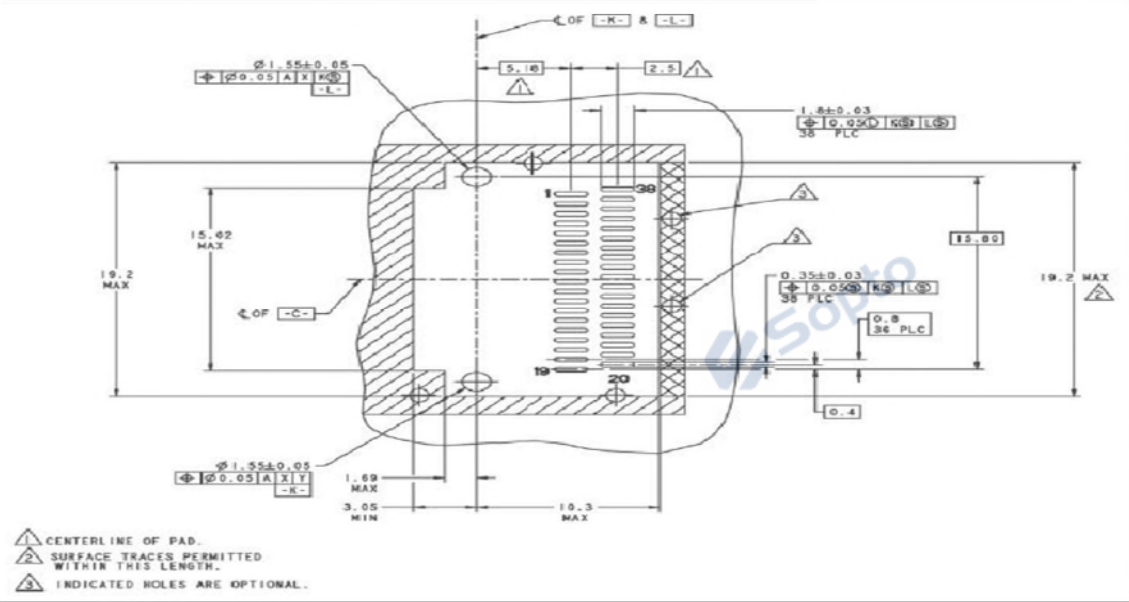
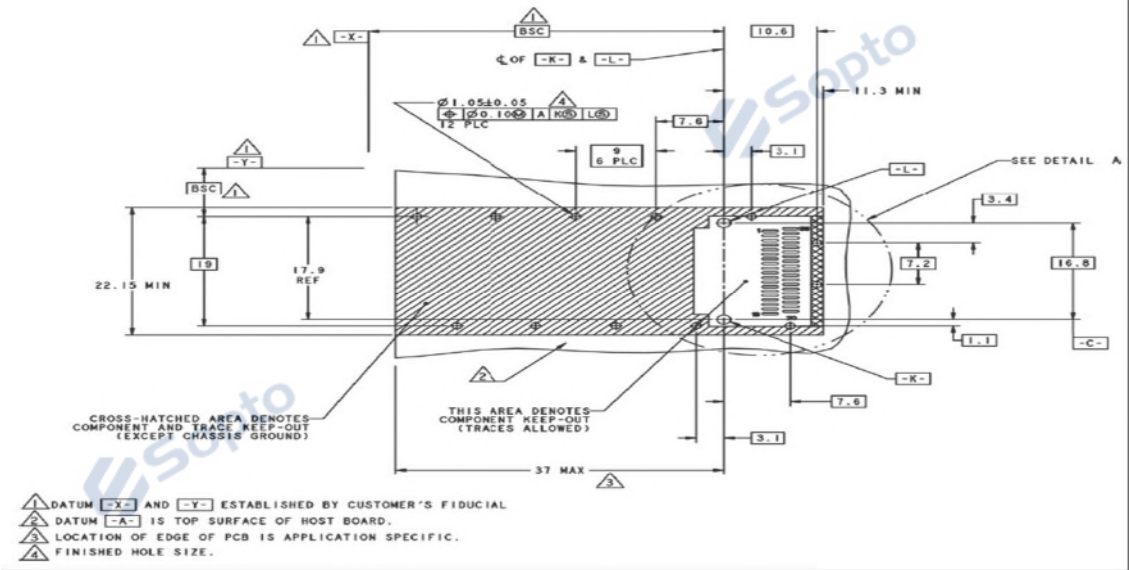

### QSFP Copper Module Outline for System Design

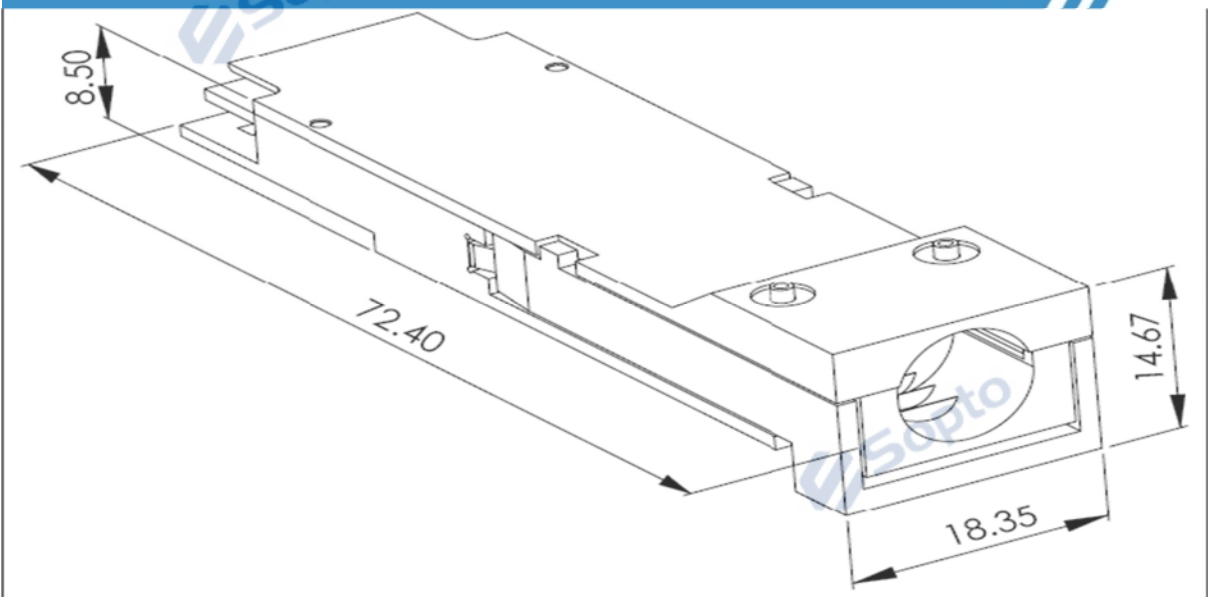

## Mechanical Dimensions

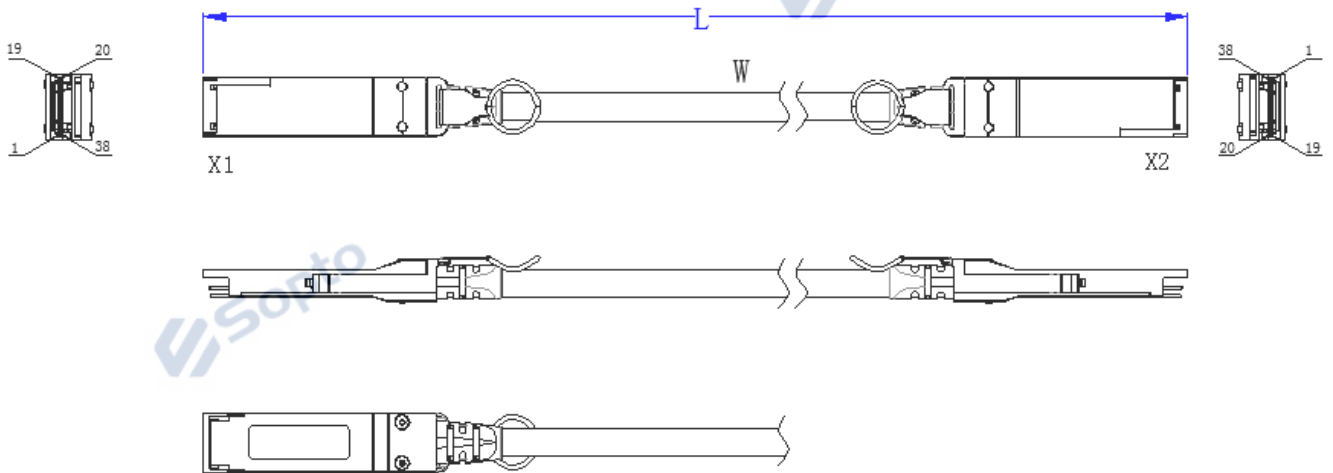

Unit:mm

## Ordering information

Part Number	Description	Cable Length (m)	AWG
SPH-QSFP+C0.5-30	40G QSFP+ to QSFP+	0.5	30
SPH-QSFP+C1-30	40G QSFP+ to QSFP+	1	30
SPH-QSFP+C2-30	40G QSFP+ to QSFP+	2	30
SPH-QSFP+C3-XX	40G QSFP+ to QSFP+	3	XX=28 or 30
SPH-QSFP+C4-28	40G QSFP+ to QSFP+	4	28
SPH-QSFP+C5-28	40G QSFP+ to QSFP+	5	28
SPH-QSFP+C7-24	40G QSFP+ to QSFP+	7	24

Note:

- 1、 Default Jacket Material is PVC.
- 2、 Default operating case temperature is 0 ~ 70°C. If you need -40 ~ 85°C products, add "T" after Part Number .
- 3、 If you need more customized services, please contact us.

E-mail: [sales@sopto.com](mailto:sales@sopto.com)

Web : <http://www.sopto.com>