

40G QSFP+ to 4 SFP+ Passive Copper Cable



Overview

SOPTO QSFP+ (Quad Small Form-factor Pluggable Plus) copper direct-attach cables are suitable for very short distances and offer a highly cost-effective way to establish a 40-Gigabit link between QSFP+ ports of QSFP+ switches within racks and across adjacent racks. These cables are used for 40GbE and Infiniband standards, to maximize performance. QSFP+ are designed to meet emerging data center and high performance computing application needs for a high density cabling interconnect system capable of delivering an aggregate data bandwidth of 40Gb/s. This interconnect system is fully compliant with existing industry standard specifications such as the QSFP MSA and IBTA (InfiniBand Trade Association). The QSFP+ cables support the bandwidth transmission requirements as defined by IEEE 802.3ba (40 Gb/s) and Infiniband QDR (4x10 Gb/s per channel) specifications.

Features

QSFP to 4x SFP+ Splitter Cable offers IT professionals a cost-effective interconnect solution for merging 40G QSFP and 10G SFP+ enabled host adapters, switches and servers.

For typical applications, users can install this splitter cable between an available QSFP port on their 40 Gigabit/s rated switch and feed up to four upstream 10GbE-SFP+ enabled switches. Each QSFP-SFP+ splitter cable features a single QSFP connector (SFF-8436) rated for 40-Gb/s on one end and (4) SFP+ connectors (SFF-8431), each rated for 10-Gb/s, on the other.

QSFP to 4 SFP+ Splitter Cables that designs and sources every subassembly in-house guaranteeing complete control over product performance, quality and consistency. Examples include our widely

respected board-as-connector platform which is direct-welded to the wire and encased in a robust Zinc-Nickel backshell for superior crosstalk and EMI performance.

Specifications

- Connector A: (1) QSFP 40.0 Gbps Rated Connector (SFF-8436 Compliant)
- Connector B: (4) SFP+ 10.0 Gbps Rated Connectors (SFF-8431 Compliant)
- Economically Links up a QSFP port with an Upstream 10GbE-SFP+ Switch
- Protocol agnostic support of 40GbE, QDR InfiniBand, SAS & Fibre Channel
- Up to 10.3125 Gbps transfer rate per SFP+ channel (40 Gbps aggregate)
- Robust Zinc die-cast SFP+ & QSFP connectors with pull-to-release latching
- Bridge the gap between your 10G and 40G capable switches/host adapters
- Low cross-talk and pair-to-pair skew maintains signal integrity
- Fully compliant to the latest SFP+ & QSFP MSA (Multi-Source-Agreement)
- Supports all current 10-Gigabit Ethernet and 40-Gigabit Ethernet standards
- Designated form factor and electrical compliance for QDR InfiniBand
- The perfect direct attached storage splitter cable for Fibre Channel & SAS
- Enjoy a reduced power budget and lower port cost compared to optical
- Fully RoHS compliant for environmental protection

Applications

- InfiniBand SDR, DDR
- Ethernet 1G, 10G
- FibreChannel
- Rack-to-Rack, Shelf-to-Shelf Interconnect
- Networking
- Storage
- Hubs, switches, routers, servers

Absolute Maximum Ratings

Parameter	Symbol	Min	Max	Unit	Note
Storage Temperature	Tst	-40	125	degC	
Relative Humidity (non-condensation)	RS	-	85	%	
Operating Case Temperature	Topc	-5	75	degC	1

Supply Voltage	VCC3	-0.3	3.6	V	
Voltage on LVTTTL Input	Vilvttl	-0.3	VCC3 +0.2	V	

NOTE: Stress or conditions exceed the above range may cause permanent damage to the device. This is a stress rating only and functional operation of the device at these or any other conditions above those listed in the operational sections of this specification is not applied. Exposure to absolute maximum rating conditions for extended periods may affect device reliability.

Absolute Maximum Ratings

Parameter	Symbol	Min	Max	Unit
Operating Case Temperature	Topc	-5	75	degC
Relative Humidity (non-condensation)	RS	-	85	%
Supply Voltage	VCC3	3.135	3.465	V
Power Supply Current	ICC3	750	-	mA
Total Power Consumption	Pd	-	2.0	W

Pin Assignments and Descriptions

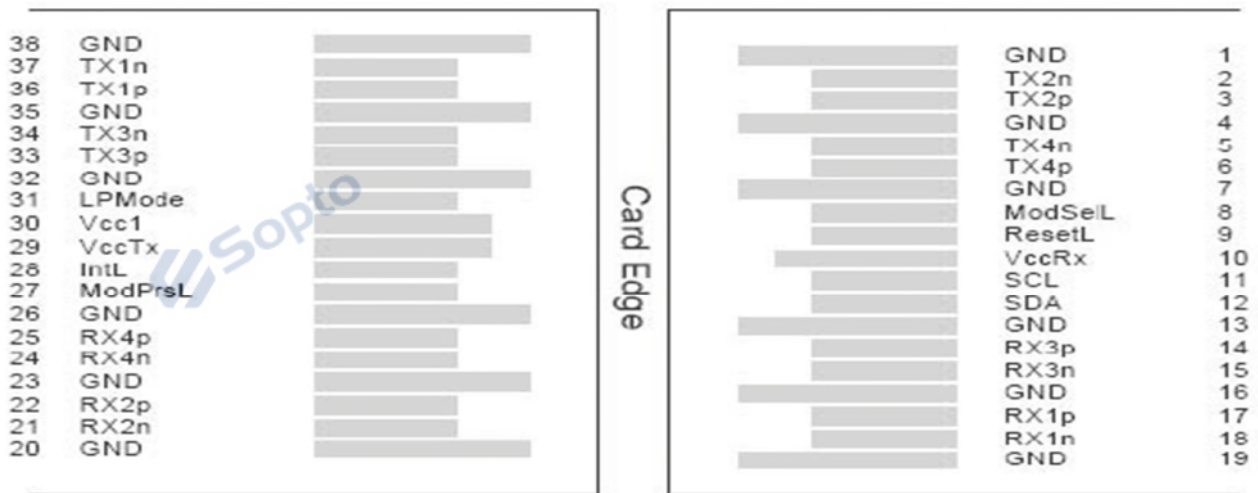

Top Side
Viewed from Top

Bottom Side
Viewed from Bottom

PIN	Logic	Symbol	Name/Description	Note
1		GND	Ground	1
2	CML-I	Tx2n	Transmitter Inverted Data Input	

3	CML-I	Tx2p	Transmitter Non-Inverted Data output	
4		GND	Ground	1
5	CML-I	Tx4n	Transmitter Inverted Data Input	
6	CML-I	Tx4p	Transmitter Non-Inverted Data output	
7		GND	Ground	1
8	LVTLL-I	ModSelL	Module Select	
9	LVTLL-I	ResetL	Module Reset	
10		Vcc Rx	+ 3.3V Power Supply Receiver	2
11	LVC MOS-I/O	SCL	2-Wire Serial Interface Clock	
12	LVC MOS-I/O	SDA	2-Wire Serial Interface Data	
13		GND	Ground	
14	CML-O	Rx3p	Receiver Non-Inverted Data Output	
15	CMLO	Rx3n	Receiver Inverted Data Output	
16		GND	Ground	1
17	CMLO	Rx1p	Receiver Non-Inverted Data Output	
18	CMLO	Rx1n	Receiver Inverted Data Output	
19		GND	Ground	1
20		GND	Ground	1
21	CMLO	Rx2n	Receiver Inverted Data Output	
22	CMLO	Rx2p	Receiver Non-Inverted Data Output	
23		GND	Ground	1
24	CMLO	Rx4n	Receiver Inverted Data Output	1
25	CMLO	Rx4p	Receiver Non-Inverted Data Output	
26		GND	Ground	1
27	LVTTL0	ModPrsL	Module Present	
28	LVTTL0	IntL	Interrupt	
29		Vcc Tx	+3.3 V Power Supply transmitter	2
30		Vcc1	+3.3 V Power Supply	2
31	LVTTL1	LPMODE	Low Power Mode	
32		GND	Ground	1
33	CMLI	Tx3p	Transmitter Non-Inverted Data Input	
34	CMLI	Tx3n	Transmitter Inverted Data Output	
35		GND	Ground	1
36	CMLI	Tx1p	Transmitter Non-Inverted Data Input	
37	CMLI	Tx1n	Transmitter Inverted Data Output	
38		GND	Ground	1

NOTE:

1. GND is the symbol for signal and supply (power) common for QSFP modules. All are common within the QSFP module and all module voltages are referenced to this potential otherwise noted. Connect these directly to the host board signal common ground plane.

2. Vcc Rx, Vcc1 and Vcc Tx are the receiver and transmitter power suppliers and shall be applied concurrently. Recommended host board power supply filtering is shown below. Vcc Rx, Vcc1 and Vcc Tx may be internally connected within the QSFP transceiver module in any combination. The connector pins are each rated for a maximum current of 500mA.

A typical host board mechanical layout for attaching the QSFP transceiver is presented below. The recommended host electrical connector should be a 38-pin IPASS right angle connector assembly and the cage assembly should be QSFP single cage.

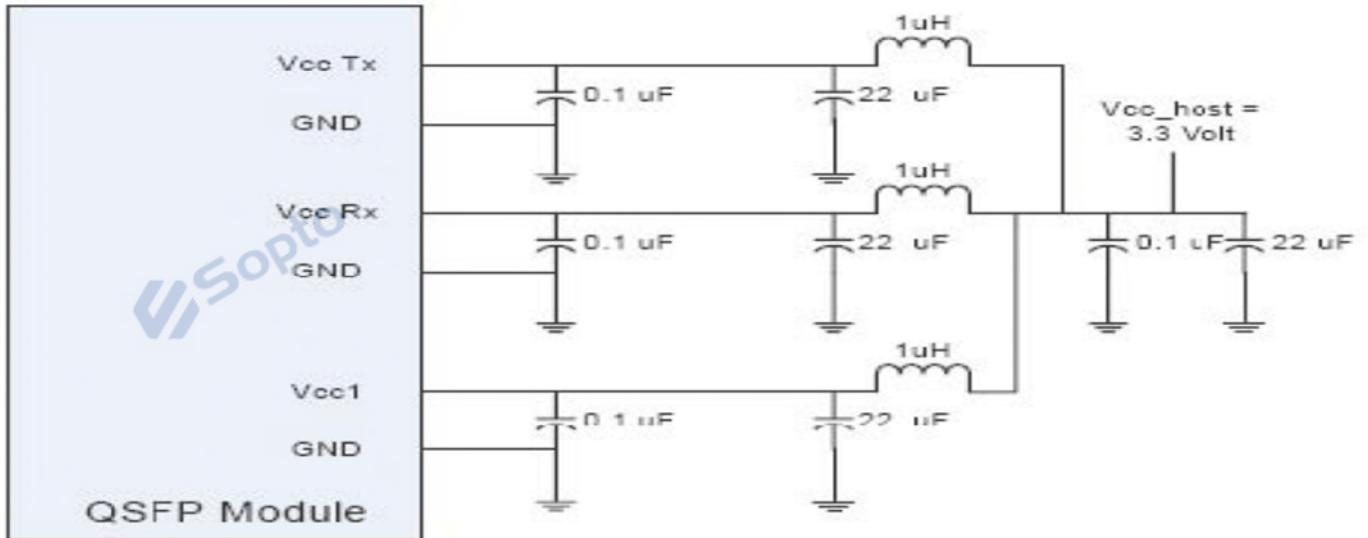

Recommended PCB layout Specifications

A typical host board mechanical layout for attaching the QSFP transceiver is presented below. The recommended host electrical connector should be a 38-pin IPASS right angle connector assembly and the cage assembly should be QSFP single cage.

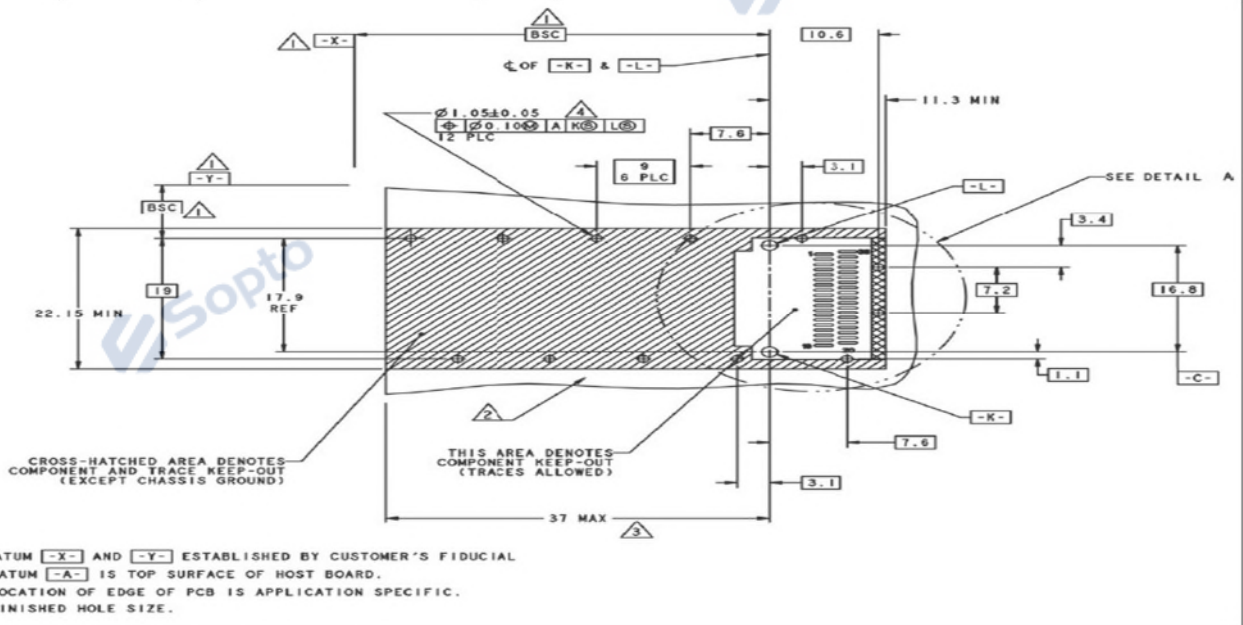

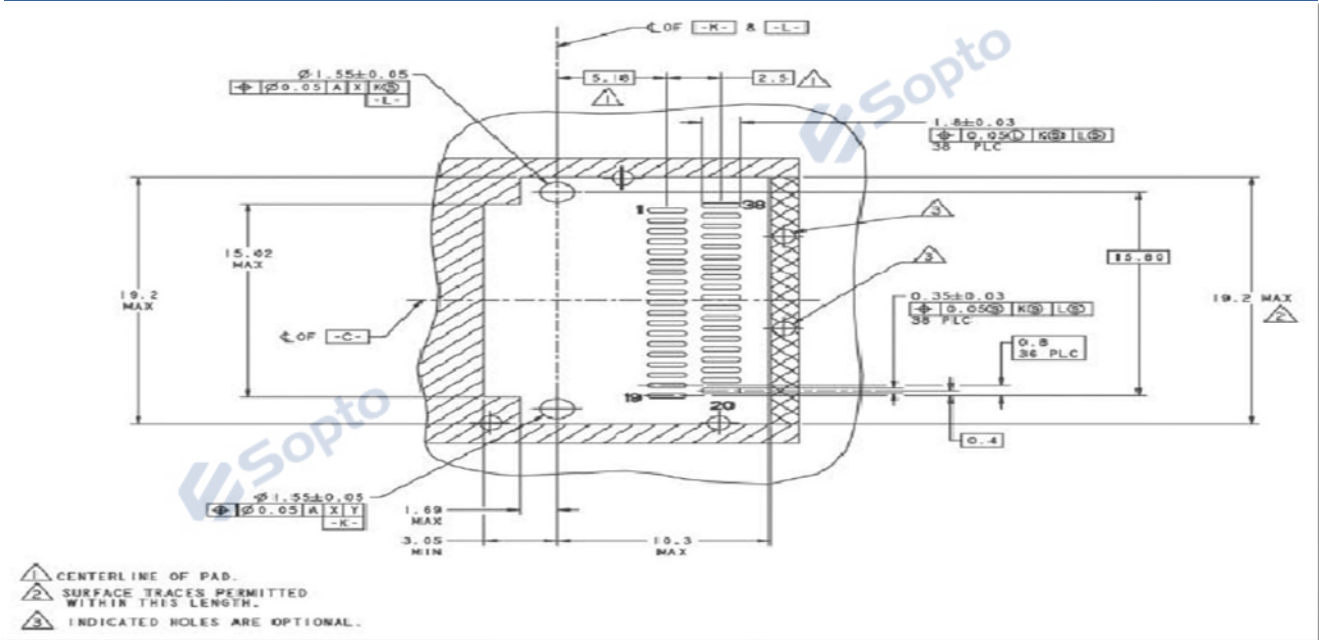

Mechanical Dimensions

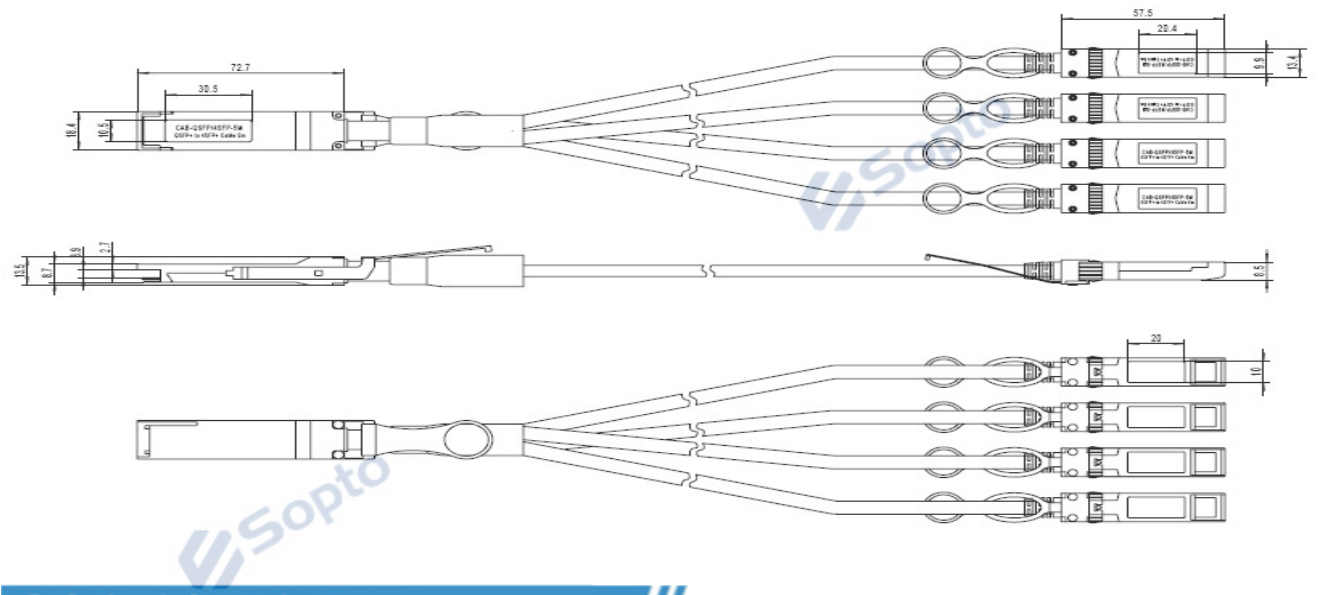

Ordering information

Part Number	Description	Cable Length (m)	AWG
SPH-Q/4SFP+C1-30	QSFP+ to 4 SFP+	1	30
SPH-Q/4SFP+C2-30	QSFP+ to 4 SFP+	2	30
SPH-Q/4SFP+C3-30	QSFP+ to 4 SFP+	3	30
SPH-Q/4SFP+C4-26	QSFP+ to 4 SFP+	4	26
SPH-Q/4SFP+C5-26	QSFP+ to 4 SFP+	5	26
SPH-Q/4SFP+C7-24	QSFP+ to 4 SFP+	7	24

Note: If you need customized services, please contact us.

Important Notice

Performance figures, data and any illustrative material provided in this data sheet are typical and must be specifically confirmed in writing by company before they become applicable to any particular order or contract. In accordance with SOPTO company policy of continuous improvement specifications may change without notice. The publication of information in this data sheet does not imply freedom from patent or other protective rights of SOPTO company or others. Further details are available from any SOPTO company sales representative.

E-mail: sales@sopto.com

Web : <http://www.sopto.com>